

## 1. PN58 Incremental Optical Encoder (Hollow Shaft)

### 1.1 Introduction:

PN58 with its unique through-shaft concentric locking device, double bearing large-aperture ultra-thin design, flexible spring plate installation, multiple electrical interfaces, and protection grade IP50, can solve the installation problems of low space limitations and slight axial movement of the motor shaft.

### 1.2 Feature:

- Encoder external diameter Ø58mm、thickness min 14mm、diameter of shaft up to Ø24mm;
- Adopt non-contact photoelectric principle;
- Reverse polarity protection;
- Short circuit protection;
- Multiple electrical interfaces available;
- Resolution per turn up to 5000PPR.

### 1.3 Application:

Servo motor, robot and automation control fields.

### 1.4 Connection:

- Radial socket (8P & 14P)
- Radial cable (standard length 1.0M)

### 1.5 Protection:

IP50

### 1.6 Weight:

About 90g

PN58-E

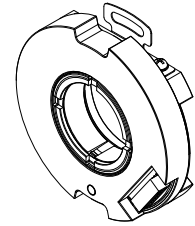

PN58-F

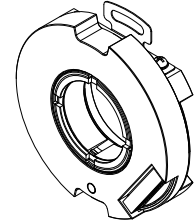

PN58-J

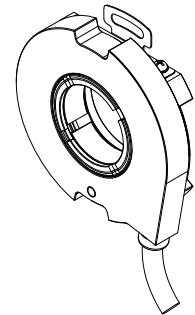

## 2. Model Selection Guide

### 2.1 Model composition(select parameters)

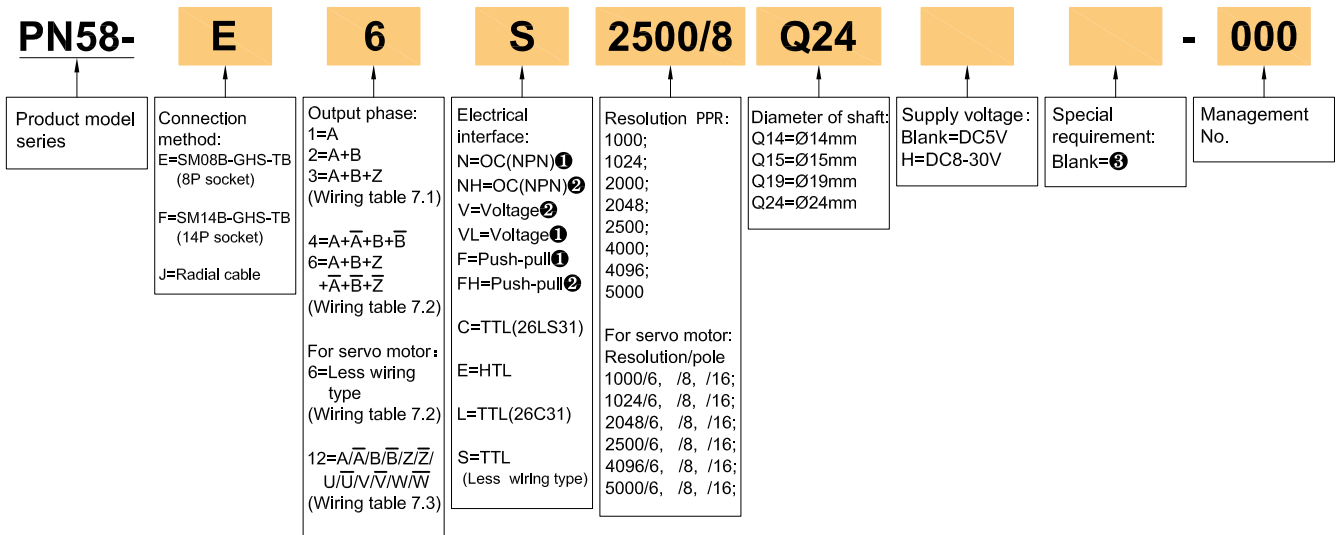

### 2.2 Note

- Z signal is low level active.
- Z signal is high level active.
- Blank means IP50, cable length is 1.0M, if need to change the length C+number, the longest is 100M (expressed by C100). For the specific length of use, pls refer to page P2 -P3 of the provision of output circuit.

3. Output Method

3.1 Incremental signal

Electrical interface	Output circuit	Output wave form
<p>OC NPN open collector circuit</p>		<p><math>a.b.c.d = \frac{T}{4} \pm 8</math></p> <p>Phase A is ahead of B by <math>\frac{T}{4} \pm 8</math>, viewing from encoder front side, direction is counterclockwise rotation. (See dimensional drawings)</p> <p>CCW direction →</p> <p>Z signal is low level active</p>
<p>Voltage</p>		<p><math>a.b.c.d = \frac{T}{4} \pm 8</math></p> <p>Phase A is ahead of B by <math>\frac{T}{4} \pm 8</math>, viewing from encoder front side, direction is counterclockwise rotation. (See dimensional drawings)</p> <p>CCW direction →</p> <p>Z signal is high level active</p>
<p>Push-pull</p>		<p><math>a.b.c.d = \frac{T}{4} \pm 8</math></p> <p>Phase A is ahead of B by <math>\frac{T}{4} \pm 8</math>, viewing from encoder front side, direction is clockwise rotation. (See dimensional drawings)</p> <p>CW direction →</p>
<p>TTL (DC5V)</p> <p>HTL (DC8-30V)</p>		<p><math>a.b.c.d = \frac{T}{4} \pm 8</math></p> <p>Phase A is ahead of B by <math>\frac{T}{4} \pm 8</math>, viewing from encoder front side, direction is clockwise rotation. (See dimensional drawings)</p> <p>CW direction →</p>

3.2 For servo motor(with UVW)

Electrical interface	Output circuit	Output wave form																																																																	
<p>TTL (DC5V)</p>																																																																			
<p>TTL (DC5V) (Less wiring type)</p>	<div style="display: flex; justify-content: space-between;"> <div style="width: 45%;"> <p>26LS31, 26C31 Transmission distance 200m Max</p> <p><b>Symbol signification</b></p> <ul style="list-style-type: none"> <li>★: indicate position of UVW channel</li> <li>☆: position to start counting ABZ channel</li> <li>□: non-using zone</li> <li>HZ: high impedance</li> </ul> </div> <div style="width: 50%;"> <table border="1" style="width: 100%; border-collapse: collapse; text-align: center;"> <thead> <tr> <th rowspan="2">No.</th> <th rowspan="2">Function Color</th> <th colspan="3">Mode</th> </tr> <tr> <th>1</th> <th>2</th> <th>3</th> </tr> </thead> <tbody> <tr> <td>1</td> <td>white</td> <td>HZ</td> <td>U</td> <td>A</td> </tr> <tr> <td>2</td> <td>white/black</td> <td>HZ</td> <td><math>\bar{U}</math></td> <td><math>\bar{A}</math></td> </tr> <tr> <td>3</td> <td>green</td> <td>HZ</td> <td>V</td> <td>B</td> </tr> <tr> <td>4</td> <td>green/black</td> <td>HZ</td> <td><math>\bar{V}</math></td> <td><math>\bar{B}</math></td> </tr> <tr> <td>5</td> <td>yellow</td> <td>HZ</td> <td>W</td> <td>Z</td> </tr> <tr> <td>6</td> <td>yellow/black</td> <td>HZ</td> <td><math>\bar{W}</math></td> <td><math>\bar{Z}</math></td> </tr> <tr> <td>7</td> <td>red</td> <td colspan="3">DC+5V</td> </tr> <tr> <td>8</td> <td>black</td> <td colspan="3">OV</td> </tr> <tr> <td>0</td> <td>shielding</td> <td colspan="3">GND</td> </tr> </tbody> </table> </div> </div>	No.	Function Color	Mode			1	2	3	1	white	HZ	U	A	2	white/black	HZ	$\bar{U}$	$\bar{A}$	3	green	HZ	V	B	4	green/black	HZ	$\bar{V}$	$\bar{B}$	5	yellow	HZ	W	Z	6	yellow/black	HZ	$\bar{W}$	$\bar{Z}$	7	red	DC+5V			8	black	OV			0	shielding	GND			<p>Reverse signal not shown</p> <table border="1" style="width: 100%; border-collapse: collapse; text-align: center;"> <thead> <tr> <th>pole</th> <th>g.h.j.k.m.n</th> <th>r</th> </tr> </thead> <tbody> <tr> <td>6</td> <td><math>20 \pm 1^\circ</math></td> <td><math>120^\circ</math></td> </tr> <tr> <td>8</td> <td><math>15 \pm 1^\circ</math></td> <td><math>90^\circ</math></td> </tr> <tr> <td>16</td> <td><math>7.5 \pm 1^\circ</math></td> <td><math>45^\circ</math></td> </tr> </tbody> </table> <p>a.b.c.d = <math>\frac{T}{4} \pm \frac{T}{8}</math>  e = <math>T \pm \frac{T}{2}</math>  f: center of phase Z to rise point of phase U, that is <math>\pm 1^\circ</math></p> <p>CW direction <math>\rightarrow</math></p> <p>Viewed from encoder front side direction is clockwise rotation. (See dimensional drawings)</p>	pole	g.h.j.k.m.n	r	6	$20 \pm 1^\circ$	$120^\circ$	8	$15 \pm 1^\circ$	$90^\circ$	16	$7.5 \pm 1^\circ$	$45^\circ$
No.	Function Color			Mode																																																															
		1	2	3																																																															
1	white	HZ	U	A																																																															
2	white/black	HZ	$\bar{U}$	$\bar{A}$																																																															
3	green	HZ	V	B																																																															
4	green/black	HZ	$\bar{V}$	$\bar{B}$																																																															
5	yellow	HZ	W	Z																																																															
6	yellow/black	HZ	$\bar{W}$	$\bar{Z}$																																																															
7	red	DC+5V																																																																	
8	black	OV																																																																	
0	shielding	GND																																																																	
pole	g.h.j.k.m.n	r																																																																	
6	$20 \pm 1^\circ$	$120^\circ$																																																																	
8	$15 \pm 1^\circ$	$90^\circ$																																																																	
16	$7.5 \pm 1^\circ$	$45^\circ$																																																																	
<p><b>Timing Chart</b></p>																																																																			

4. Electrical Parameter

Parameter / Item	Output type	OC	Voltage	Push-pull	TTL	TTL (Less wiring type)	HTL
Supply voltage		DC+5V±5%; DC8V-30V±5%			DC+5V±5%		DC8-30V±5%
Consumption current		100mA Max			120mA Max		
Allowable ripple		≤3%rms					
Top response frequency		100KHz			300KHz		500KHz
Output capacity	Output current	Input	≤30mA	Load resistance 2.2K	≤30mA	≤±20mA	≤±50mA
		Output	—		≤10mA		
	Output voltage	"H"	—	—	≥ $\left[ \begin{matrix} \text{Supply voltage} \\ -2.5V \end{matrix} \right]$	≥2.5V	≥Vcc-3 Vbc
		"L"	≤0.4V	≤0.7V(less than 20mA)	≤0.4V(30mA)	≤0.5V	≤ 1V Vbc
Load voltage		≤DC30V	—		—		
Rise & Fall time		Less than 2us(cable length: 2m)			Less than 1us(Cable length: 2m)		
Insulation strength		AC500V 60s					
Insulation resistance		10MΩ					
Mark to space ratio		45% to 55%					
Reverse polarity protection		✓					
Short-circuit protection		—			✓❶		
Phase shift between A & B		90°±10° ( frequency in low speed)					
		90°±20° ( frequency in high speed)					
Delay motion time ❷		—				510±220ms	—
GND		Not connect to encoder					

❶ Short-circuit to another channel or GND permitted for max.30s.

❷ Phase A.B.Z are back of phase U.V.W when power on.

## 5. Mechanical Specification

Diameter of shaft	Ø14mm; Ø15mm; Ø19mm; Ø24mm(optional)
Starting torque	Less than $9.8 \times 10^{-3} \text{N}\cdot\text{m}$
Inertia moment	Less than $6.5 \times 10^{-6} \text{kg}\cdot\text{m}^2$
Shaft load	Radial 30N; Axial 10N
Slew speed	$\leq 5000 \text{ rpm}$
Bearing Life	$1.5 \times 10^9$ revs at rated load(100000hrs at 2500RPM)
Material	Base: Die cast aluminum
Weight	About 90g

## 6. Environmental Parameter





Environmental temperature	Operating: $-20 \sim +85^\circ\text{C}$ (repeatable winding cable: $-10^\circ\text{C}$ ); Storage: $-20 \sim +90^\circ\text{C}$
Environmental humidity	Operating and storage: 35~85%RH(noncondensing)
Vibration(Endurance)	Amplitude 0.75mm,5~55Hz,2h for X,Y,Z direction individually
Shock(Endurance)	$490\text{m/s}^2$ 11ms three times for X,Y,Z direction individually
Protection	IP50

7. Wiring Table

7.1 OC / Voltage







Socket pin No.	Signal						Supply voltage	
	1	2	3	4	5	6	7	8
Wire color	White	-	Green	-	Yellow	-	Red	Black
Function	A	-	B	-	Z	-	Up	0V

7.2 TTL / HTL / Push-pull / Less wiring type

Socket pin No.	Signal						Supply voltage	
	1	2	3	4	5	6	7	8
Wire color	White	White/BK	Green	Green/BK	Yellow	Yellow/BK	Red	Black
Function	A+ (U+)*	A- (U-)*	B+ (V+)*	B- (V-)*	Z+ (W+)*	Z- (W-)*	Up	0V
Twisted-paired cable								

\* For the functional status in less wiring mode, refer to the functional mode wiring table for output circuit on page3.

7.3 For servo motor

Socket pin No.	Signal												Supply voltage	
	1	2	3	4	5	6	7	8	9	10	11	12	13	14
Wire color	Blue	Blue/Bk	Grey	Grey/Bk	Pink	Pink/Bk	Yellow	Yellow/BK	Green	Green/BK	White	White/BK	Black	Red
Function	U+	U-	V+	V-	W+	W-	Z+	Z-	B+	B-	A+	A-	0V	Up
Twisted-paired cable														

Up=Supply voltage.

Shield wire is not connected to the internal circuit of encoder.

8. Socket & Cable

8.1 Socket pin definition

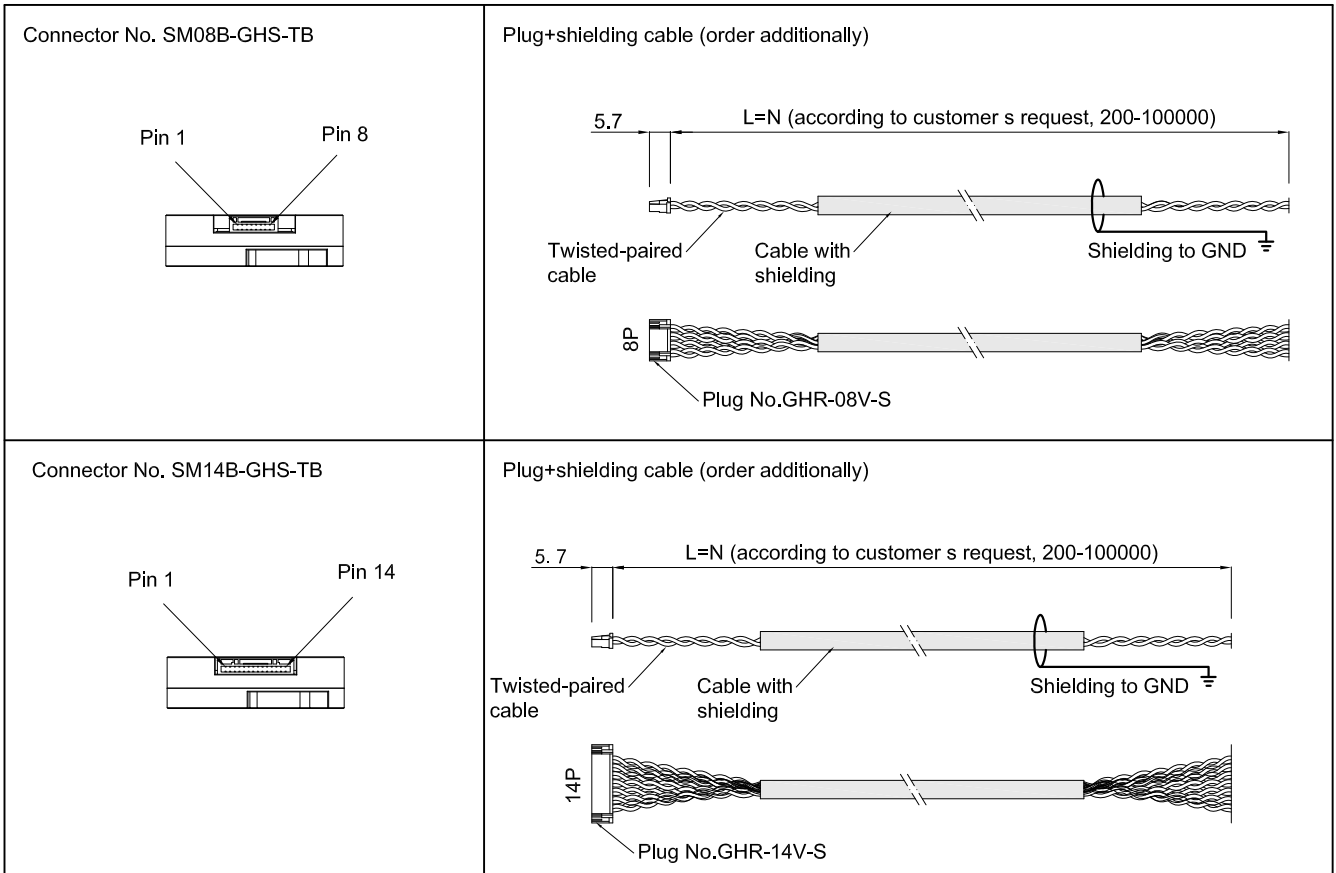

8.2 Radial Cable Schematic

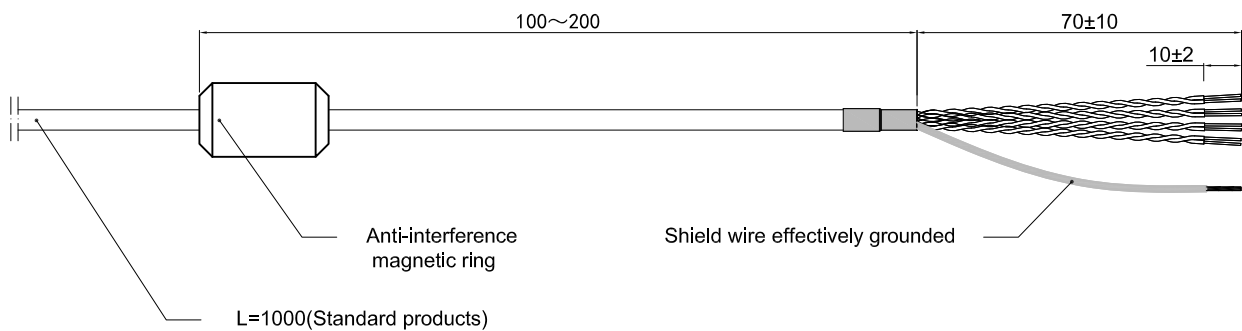

Unit: mm

9. Basic Dimension

9.1 PN58-E

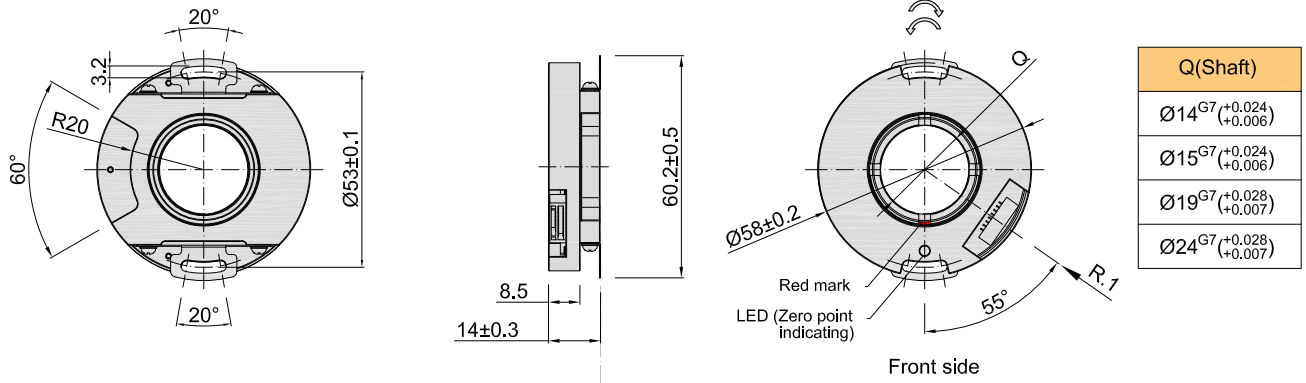

9.2 PN58-F (other dimension are the same as PN58-E)

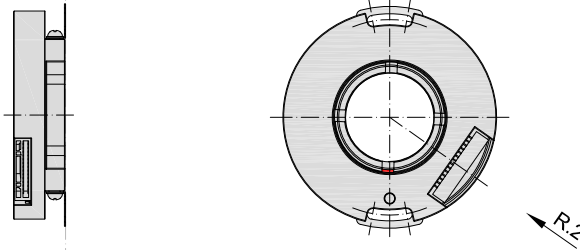

9.3 PN58-J (other dimension are the same as PN58-E)

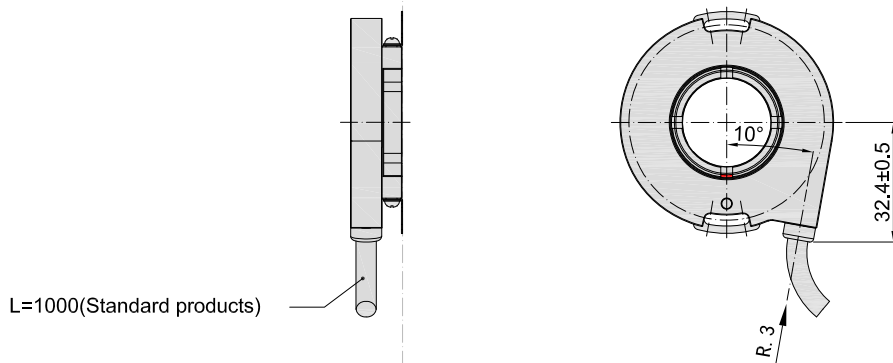

9.4 Installation shaft specification

d(motor shaft)	Mounting screws
Ø14 <sub>g6</sub> <sup>(-0.006/-0.017)</sup>	Inner hexagon bolt +flat washer Specification: M3*6
Ø15 <sub>g6</sub> <sup>(-0.006/-0.017)</sup>	Material: stainless steel
Ø19 <sub>g6</sub> <sup>(-0.007/-0.020)</sup>	Quantity: 2
Ø24 <sub>g6</sub> <sup>(-0.007/-0.020)</sup>	

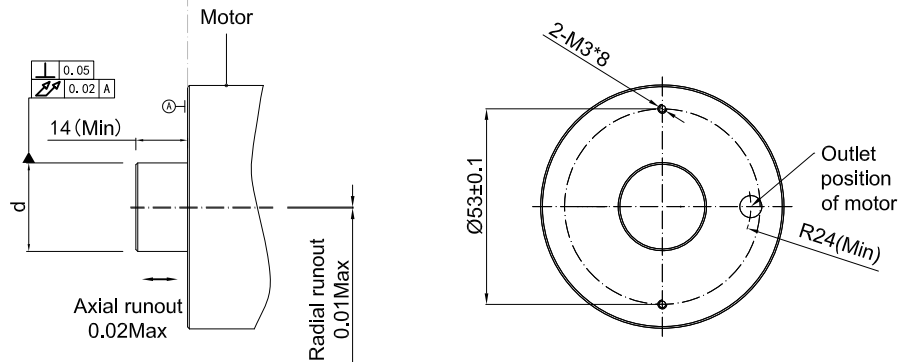

Unit: mm

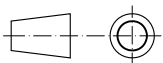

↻ = Shaft rotate direction of incremental TTL & HTL signal output  
 ↻ = Shaft rotate direction of OC signal output

R1 = Radial socket 8P (SM08B-GHS-TB).  
 R2 = Radial socket 14P (SM14B-GHS-TB).  
 R3 = Radial cable(standard length 1M).



### 10. Assembly Steps for Servo Motor Encoder

#### 10.1 Encoder installation and zero position alignment with U.V.W

**Step 1**

- a. Before installing the encoder, first to confirm the starting zero position of the motor and lock it tightly to ensure that the motor shaft is not moving until the encoder is finished installation, otherwise the encoder and the motor's zero position cannot be aligned.
- b. Put the encoder (2) directly on the motor shaft and gently push it to the motor platform by hand.
- c. Screwed the two M3\*15 bolts (3) at the same time, but do not tighten, just enough to rotate the encoder by hand.

**Note:**

Please refer to page 8 for the matching tolerance of the encoder shaft sleeve and the motor shaft.

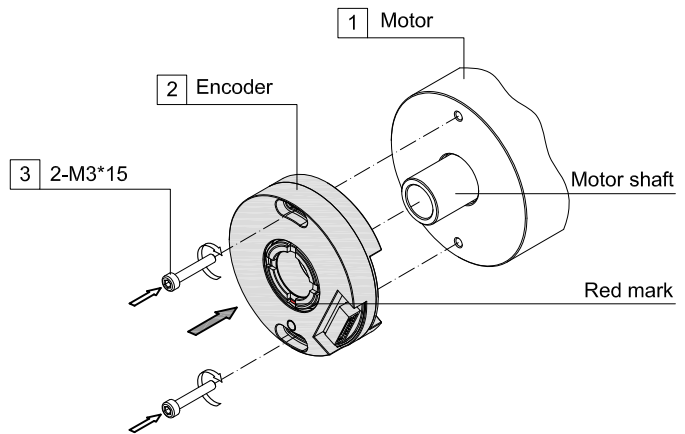

**Step 2**

- a. Fix the spanner (A) on the slot of the encoder shaft sleeve (outer ring) and then use the spanner (B) to tighten the lock nut (recommended tightening force is 13-16N.m).
- b. Pls refer to the socket connection table on page 6-7 for connection, power on after checking all are correct, please confirm again that the motor is in the zero locked state, and then turn the encoder (2) left and right by hand, observe the LED on the encoder, when it is on, the zero signal is aligned, then tighten the two M3\*15 bolts (3) and keep the LED on.

**Note:**

- \* The red mark on the shaft sleeve is always aligned with the LED indicator.
- \* After making sure that the lock nut has been tightened, put thread glue on the inner thread of the slot to prevent the screw from loosening.
- \* Because the width of the zero signal is relatively narrow, it is easy to cause displacement during the tightening process and the LED may not light up. please be patient to debug or use other testing equipments as auxiliary observation.

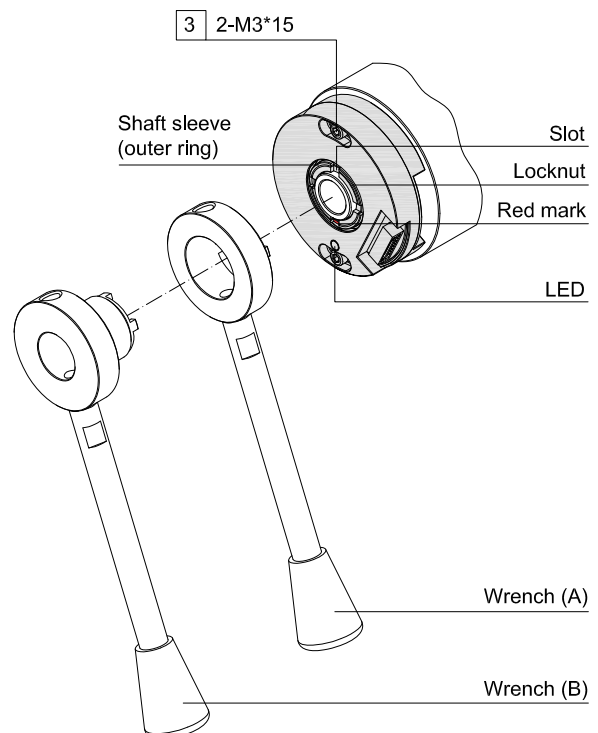

10.2 Incremental encoder installation steps

Step 1

Put the encoder (2) directly on the motor (1) shaft and gently push it to the motor platform, then screw in two M3\*15 bolts (3) and tighten them at the same time.

Note:

Please refer to page 8 for the matching tolerance of the encoder shaft sleeve and the motor shaft.

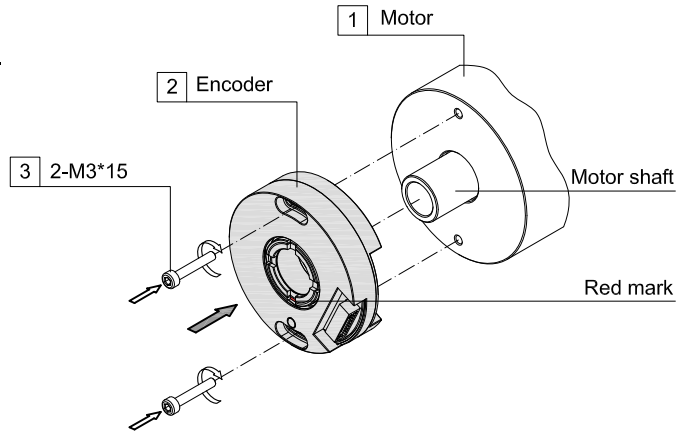

Step 2

Fix the spanner (A) on the slot of the encoder shaft sleeve (outer ring) and then use the spanner (B) to tighten the lock nut. (recommended tightening force is 13-16N.m).

Note:

- \*. The red mark on the shaft sleeve is aligned with the LED indicator light for the zero primary position. When the power is turned on and the LED light is on, it is the precise zero position.
- \*. After making sure that the lock nut has been tightened, put thread glue on the inner thread of the slot to prevent the screw from loosening.

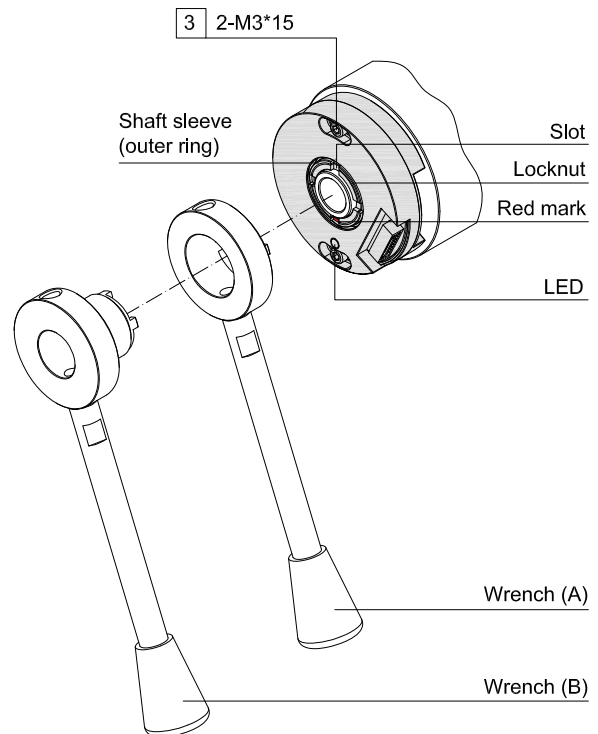

## 11. Caution

### 11.1 About vibration

Vibration act on encoder always cause wrong pulse, so we should pay attention to working place. More pulse per revolution, narrower groovy spacing of grating, more effect to encoder by vibration, when rev is low or stop, vibration act on shaft or main body would cause grating vibrating, so encoder might make wrong pulse.

### 11.2 Caution for wiring

- Use the encoder under the specified supply voltage. Please note that the supply voltage range may drop due to the wiring length.
- Do not put the encoder wiring and other power lines through the same duct, and do not use them by bundling in parallel.
- Please do not apply excessive force to the cable of encoder, or it will may be damaged.

